

No.	Panel	Section			
		Leg	Diagonal	Horizontal	Arm
1	PANEL 1	CHS Ø114.3x3.2	CHS Ø27.2x2	CHS Ø27.2x2	-
2	PANEL 2 ANTITWIST	CHS Ø114.3x3.2	CHS Ø34x2.3	CHS Ø34x2.3	CHS Ø60.5x2.3
3	PANEL 3	CHS Ø114.3x3.2	CHS Ø27.2x2	CHS Ø34x2.3	-
4	PANEL 4	CHS Ø114.3x3.2	CHS Ø27.2x2	CHS Ø27.2x2	-
5	PANEL 5 ANTITWIST	CHS Ø114.3x3.2	CHS Ø34x2.3	CHS Ø34x2.3	CHS Ø60.5x2.3
6	PANEL 6	CHS Ø114.3x3.2	CHS Ø27.2x2	CHS Ø34x2.3	-
7	PANEL 7	CHS Ø114.3x3.2	CHS Ø27.2x2	CHS Ø27.2x2	-
8	PANEL 8	CHS Ø114.3x3.2	CHS Ø27.2x2	CHS Ø34x2.3	-
9	PANEL 9	CHS Ø114.3x3.2	CHS Ø27.2x2	CHS Ø27.2x2	-
10	PANEL 10	CHS Ø114.3x3.2	CHS Ø27.2x2	CHS Ø34x2.3	-
11	PANEL 11	CHS Ø114.3x3.2	CHS Ø27.2x2	CHS Ø27.2x2	-
12	PANEL 12	CHS Ø114.3x3.2	CHS Ø27.2x2	CHS Ø27.2x2	-
13	PANEL 13	CHS Ø114.3x3.2	CHS Ø34x2.3	CHS Ø34x2.3	-

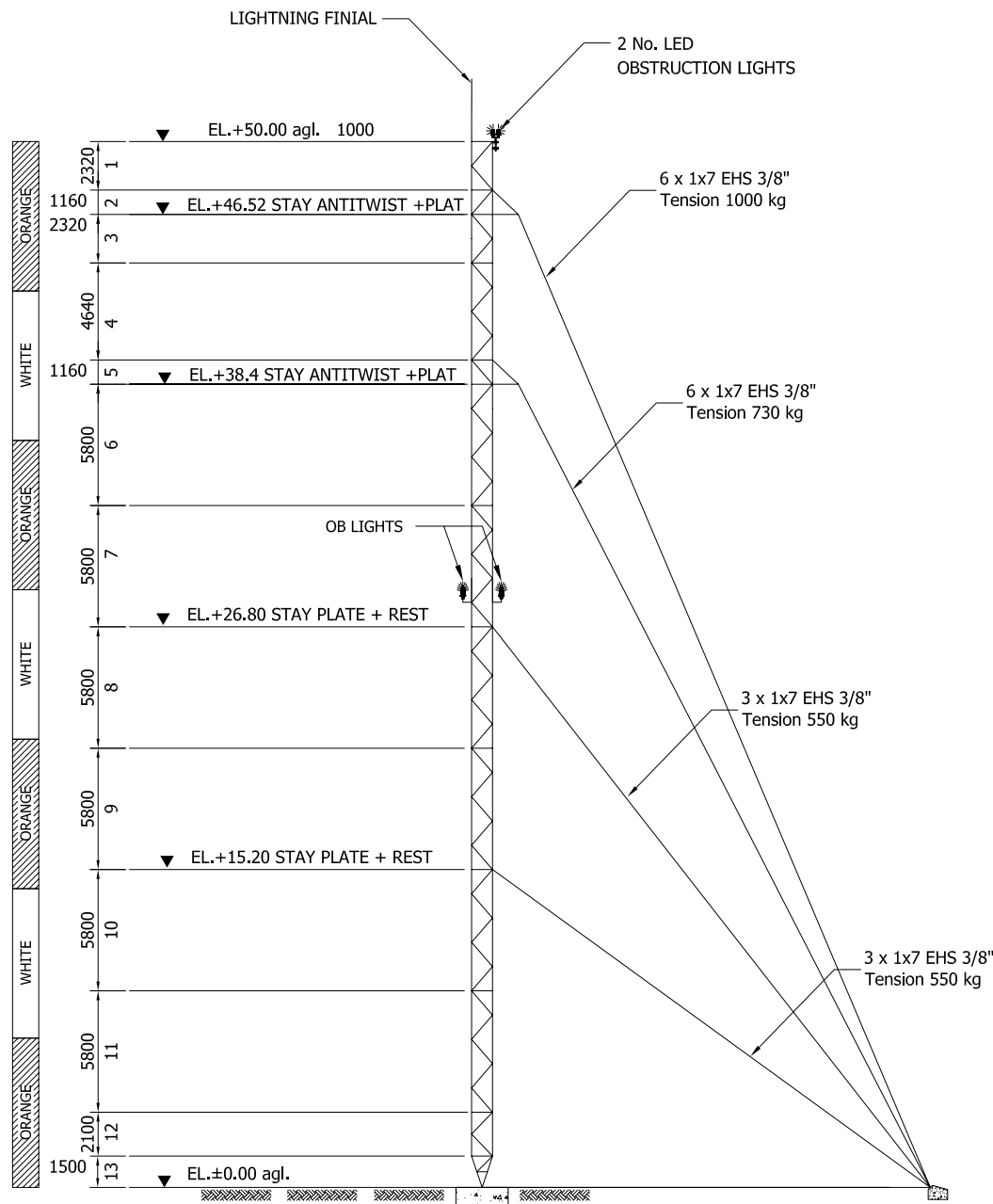

NOTE

FLANGE CONNECTION BETWEEN PANELS , 15MM PLATE, 210 OD , 6 x M16 GRADE 8.8 AT 165 PCD

REMARK CHS = CIRCULAR HOLLOW SECTION JIS G3444 (STK41)

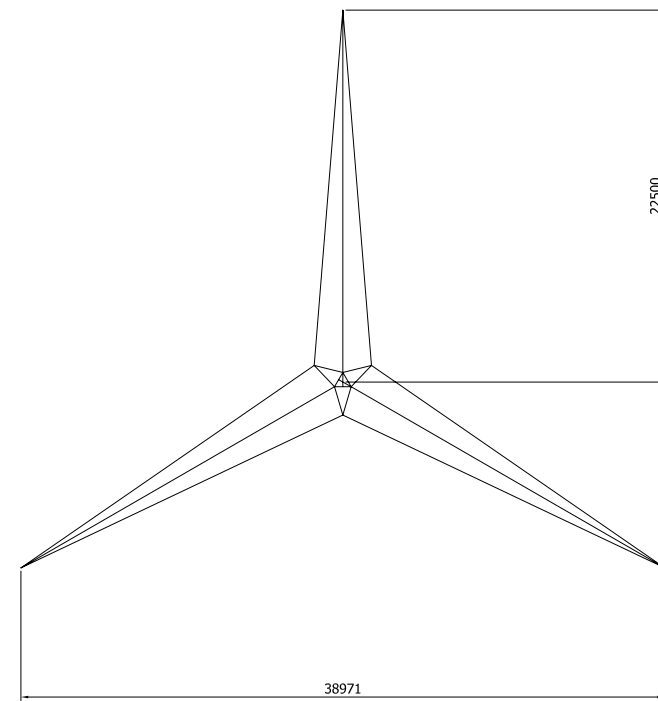

Standard Codes of Practices	ANSI/TIA 222-G:2005				
	5.0 sq.m	10.0 sq.m	15.0 sq.m	20.0 sq.m	25.0 sq.m
Antenna loading, over top 10m	5.0 sq.m	10.0 sq.m	15.0 sq.m	20.0 sq.m	25.0 sq.m
Basic wind speed, 3-s gust	57.0 m/s	45.0 m/s	38.5 m/s	34.0 m/s	31.0 m/s
Operational wind speed, 3 -s gust	54.0 m/s	45.0 m/s	38.5 m/s	34.0 m/s	31.0 m/s
Maximum deflection	<0.5 degree				

D		DRN	PHS.	PRODUCT: WX-GT100			
C		CHK	TRD.	TITLE: KEY DIAGRAM 50M GUYED MAST			
B		APP	PK				
A	05/08/2009 (ORIGINAL)	ORIGINAL SCALE	NTS	@ A3 - DO NOT SCALE THIS PRINT	THIRD ANGLE PROJECTION U.N.O.	DRG.No	MKT_GT_202
ISSUE							

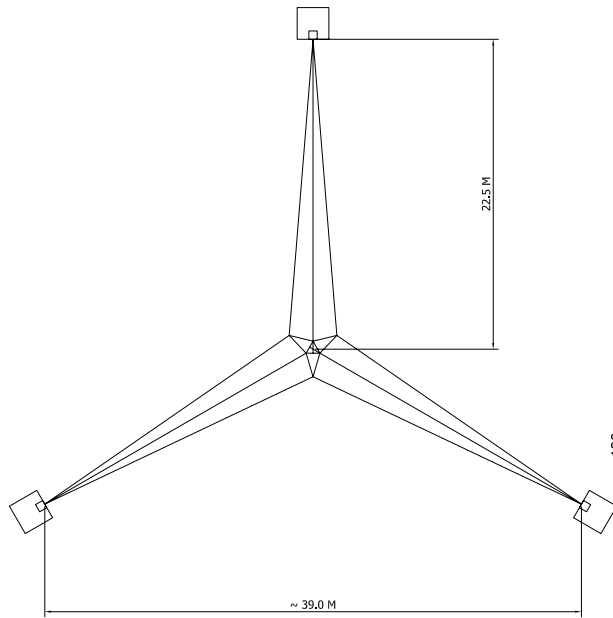

LAYOUT

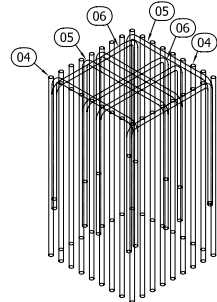

3D TOP OF COLUMN REBAR LAYOUT

NOTE: DRAWING SHOWS 600 X600 COLUMN WITH 32 T20 VERTICAL BARS FOR LESSER BARS OR BIGGER COLUMNS THEN POSITIONS OF REBAR CAN BE DIFFERENT

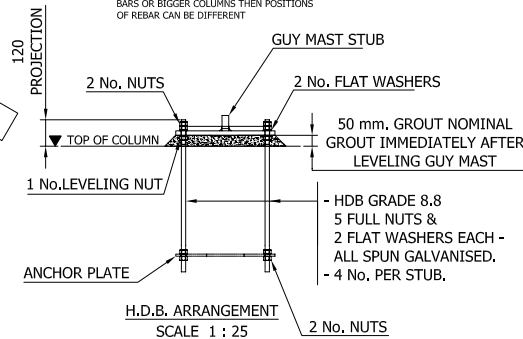

H.D.B. ARRANGEMENT
SCALE 1 : 25

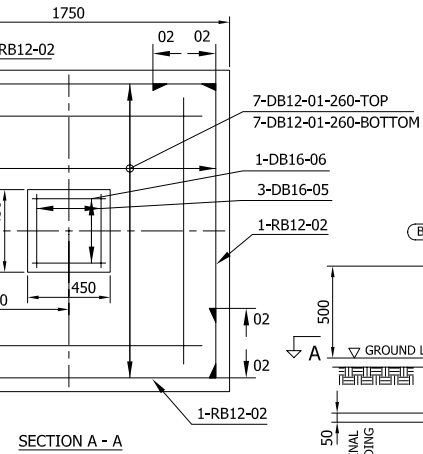

SECTION A - A

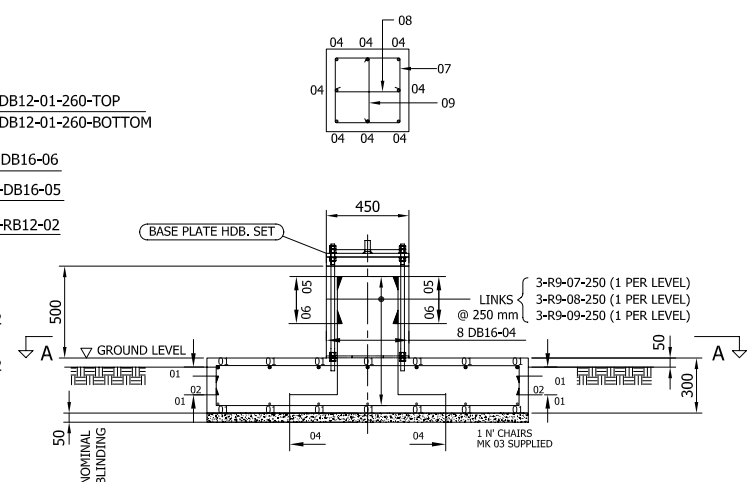

MAST BASE

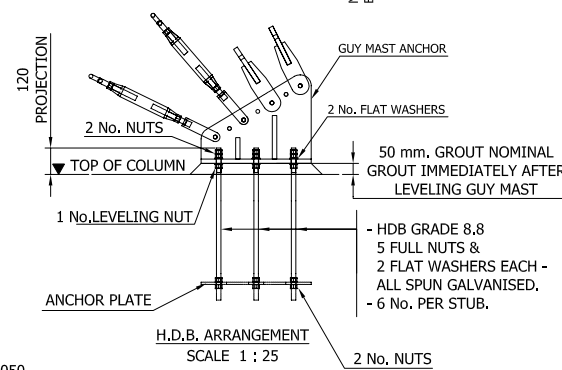

H.D.B. ARRANGEMENT
SCALE 1 : 25

NOTE FOR HDB :-
BEFORE ERECTION, ALL BASE PLATES MUST BE SET TO THE SAME LEVEL ON THE HOLDING DOWN BOLTS (H.D.B.s), THE LEVELLING NUT ON EACH H.D.B. MUST BE TIGHT TO THE UNDERSIDE OF EACH BASE PLATE DURING ERECTION. THE BASE PLATES SHOULD BE GROUTED AS SOON AS SUFFICIENT TOWER HAS BEEN ERECTED TO CONFIRM VERTICALITY; PREFERABLY BEFORE THE TOWER EXCEEDS 1/3 OF ITS HEIGHT.

NOTE :-
ALLOWABLE DESIGN BEARING PRESSURE ≥ 100 kN/m²
CONCRETE CONSTRUCTION SHALL BE IN ACCORDANCE WITH THE REQUIREMENTS OF BS.8110:1985
CEMENT SHALL BE: 'ORDINARY PORTLAND' OR 'SULPHATE RESISTING PORTLAND' (AS REQUIRED)
MAXIMUM AGGREGATE SIZE SHALL BE 20mm.
THE 28-DAY CRUSHING STRENGTH SHALL BE 30 N/mm² FOR STRUCTURAL CONCRETE, AND 15 N/mm² FOR CONCRETE FILL IN ACCORDANCE WITH BS.8110:1985.
REINFORCEMENT STEEL SHALL HAVE Fy = 400 MPa MAIN BARS, AND Fy = 240 FOR CHAIRS AND LINKS.
CONCRETE COVER SHALL BE 50mm TOP AND BOTTOM, 75mm TO SIDES, 75mm TO SIDES OF PAD, 50mm TO SIDES OF COLUMN.
A 50mm 45° CHAMFER SHALL BE FORMED ON ALL EDGES AND RE-ENTRANT ANGLES.
BEFORE PLACING CONCRETE, THE FOUNDATION SHALL BE FREE OF ANY LOOSE MATERIAL AND DELETERIOUS SUBSTANCES.
WHILST PLACING, THE CONCRETE SHALL BE PROPERLY CONSOLIDATED USING MECHANICAL VIBRATORS.

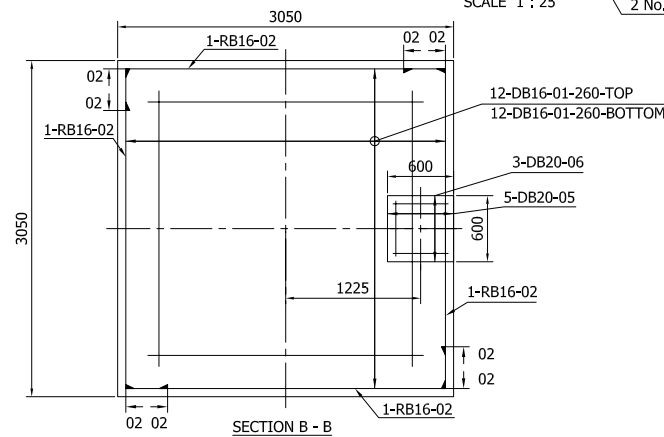

SECTION B - B

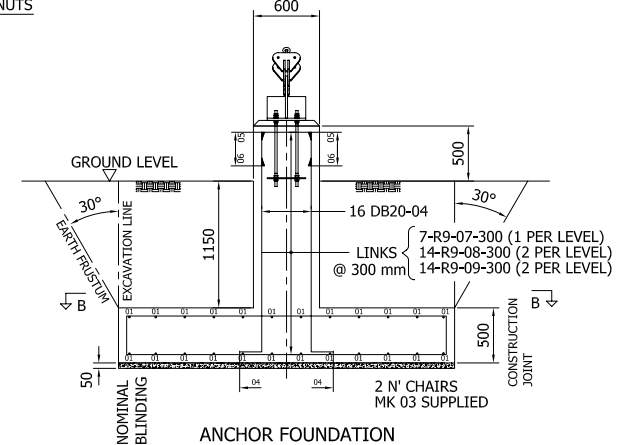

ANCHOR FOUNDATION

D	DRN	PHS.	PRODUCT:	MKT-GT100			
C	CHK	TRD.	TITLE:	GA. 50 m. GUYED MAST			
B	17/08/2009 2009/0025	APP	PK	PAD & COLUMN FOUNDATION 100 kPa			
A	11/08/2009 (ORIGINAL)	APP	PK				
ISSUE			ORIGINAL SCALE	NTS	@ A3 - DO NOT SCALE THIS PRINT	THIRD ANGLE PROJECTION U.N.O.	DRG.No MKT-GT_102

REINFORCEMENT SCHEDULE

TITLE. PAD & COLUMN FOUNDATION FOR 50-60.0 M. SHT.No. 1 OF 1
 GUY MAST BASES 100 kPa
 (REF. MKT-GT_102-104) DRG.No. MKT-GT_102-104_RE

LOCATION	BAR MK	GRADE & DIA(mm)	TOTAL No.	LENGTH OF EACH	SHAPE CODE	SKETCH OR DIMENSIONS (mm)				
						A	B	C	D	E
PAD	01	T12	28	1850	21	150	1600			
PAD	02	T12	4	2075	11	400	1575			
PAD	03	R12	1	1800	99	500	150	500	500	
COLUMN	04	T16	6	700	11	200	550			
COLUMN	05	T16	2	875	21	300	350	300		
COLUMN	06	T16	2	875	21	300	350	300		
COLUMN	07	R9	3	1660	51	350	350	130		
COLUMN	08	R9	3	700	41	100	100	350	100	100
COLUMN	09	R9	3	700	41	100	100	350	100	100

SKETCHES FOR 10+11

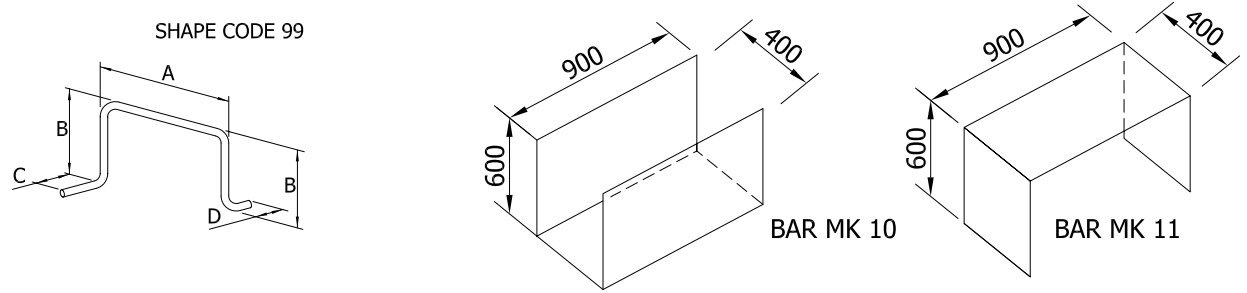

ISSUE	A					TOTAL WT. R9 = 4.58 Kg. TOTAL WT. R12 = 1.61 Kg. TOTAL WT. T12 = 53.85 Kg. TOTAL WT. T16 = 12.17 Kg. TOTAL WT. = 72.21 Kg.
DATE	13/08/2009					
DRAWN	PHS.					
CHECKED	TRD.					
APPROVED	PK.					

REINFORCEMENT SCHEDULE

TITLE. PAD & COLUMN FOUNDATION FOR 40-50.0 M. SHT.No. 1 OF 1
 GUY 100 kPa ANCHORS
 (REF. MKT-GT_100-102) DRG.No. MKT-GT_100-102_RE

LOCATION	BAR MK	GRADE & DIA(mm)	TOTAL No.	LENGTH OF EACH	SHAPE CODE	SKETCH OR DIMENSIONS (mm)				
						A	B	C	D	E
PAD	01	T16	144	3550	21	350	2900			
PAD	02	T16	12	3375	11	400	2875			
PAD	03	R12	6	2000	99	500	350	500	500	
COLUMN	04	T20	48	2050	11	200	1900			
COLUMN	05	T20	12	1725	21	650	500	650		
COLUMN	06	T20	12	1725	21	650	500	650		
COLUMN	07	R9	21	2260	51	500	500	130		
COLUMN	08	R9	42	850	41	100	100	500	100	100
COLUMN	09	R9	42	850	41	100	100	500	100	100

SKETCHES FOR 10+11

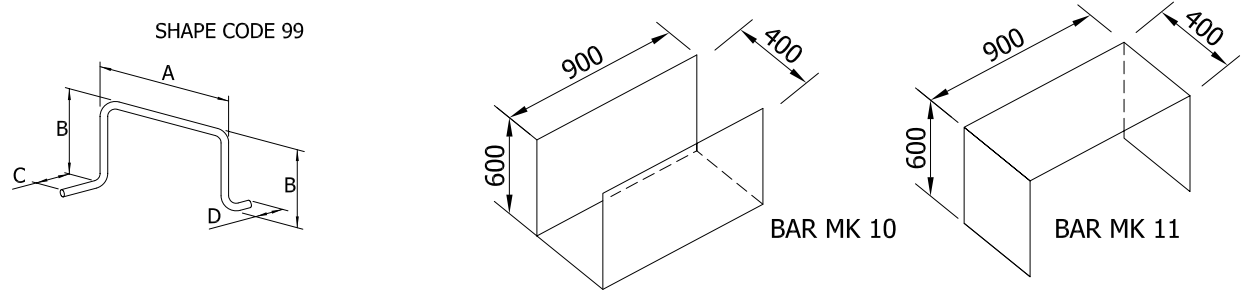

ISSUE	A										TOTAL WT. R9 = 59.31 Kg.
DATE	13/08/2009										TOTAL WT. R12 = 10.75 Kg.
DRAWN	PHS.										TOTAL WT. T16 = 871.69 Kg.
CHECKED	TRD.										TOTAL WT. T20 = 345.31 Kg.
APPROVED	PK.										TOTAL WT. = 1287.06 Kg.