

Panel	Drawing No.	Section					
		Leg	Diagonal	Horizontal	Redundant	Plan	Hip
A	WX-F200_211	HL75x75x6 4M16	L56x56x4 1M12	L45x45x4 1M12			
B	WX-F200_212	HL90x90x7 4M16	L56x56x5 2M12	L45x45x4 2M12			
C	WX-F200_213	HL100x100x7 6M16	L50x50x4 2M12	L45x45x4 2M12			
D	WX-F200_214	HL100x100x8 6M16	L50x50x4 2M12	L40x40x3 2M12			
E	WX-F200_215	HL100x100x8 6M16	L50x50x4 2M12	L40x40x3 2M12		L40x40x3 1M12	
F	WX-F200_216	HL110x110x8 8M16	L50x50x4 2M12	L40x40x3 2M12	L40x40x3 1M12	L40x40x3 1M12	L40x40x3 1M12
G	WX-F200_241	HL125x125x8 8M16	L50x50x4 2M12	L40x40x3 2M12	L40x40x3 1M12	L40x40x3 1M12	L40x40x3 1M12
H	WX-F200_246	HL125x125x10 8M16	L56x56x4 2M12	L40x40x3 2M12	L40x40x3 1M12	L40x40x3 1M12	L40x40x3 1M12

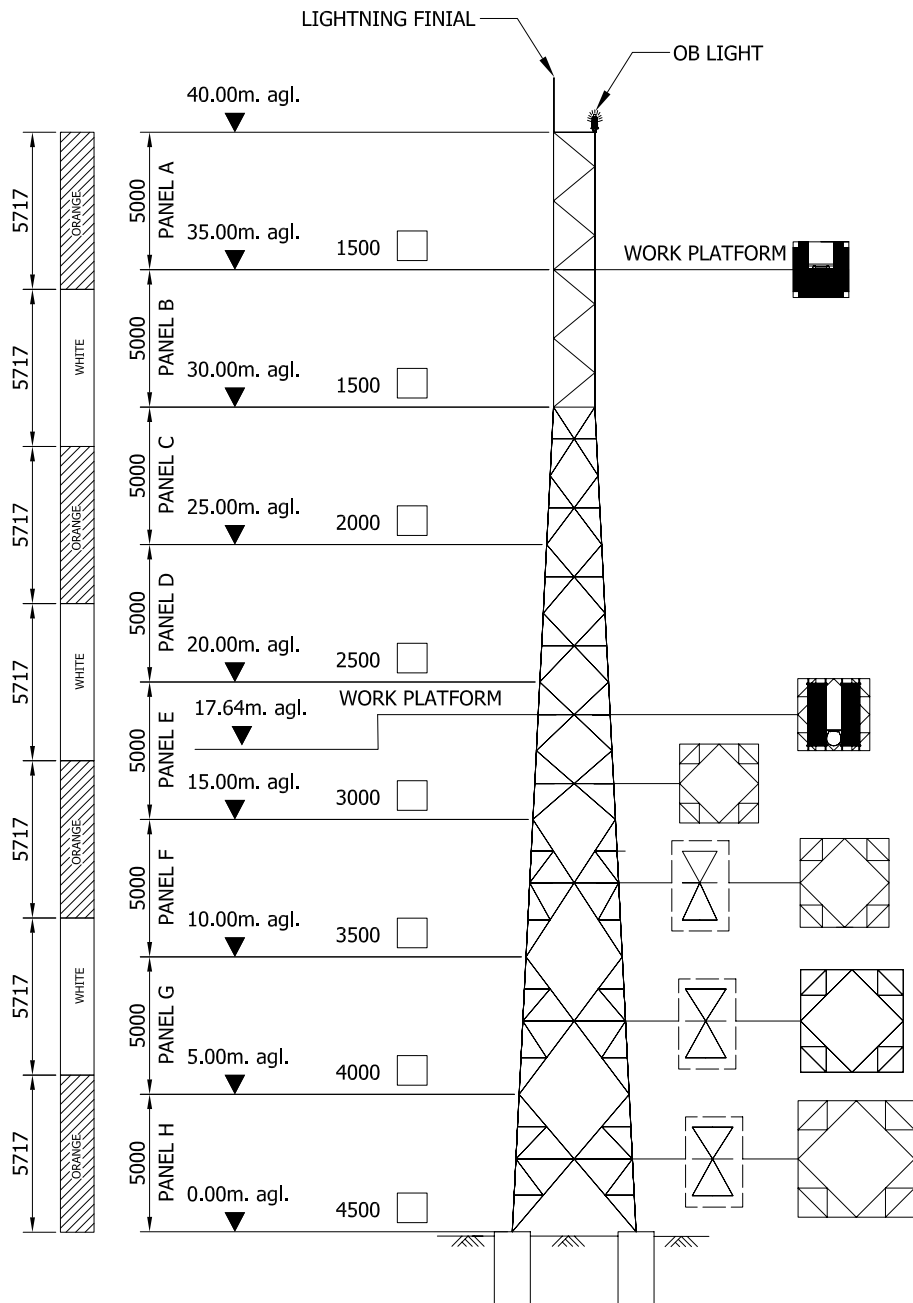

REMARK :

HL = Q345
L = Q235

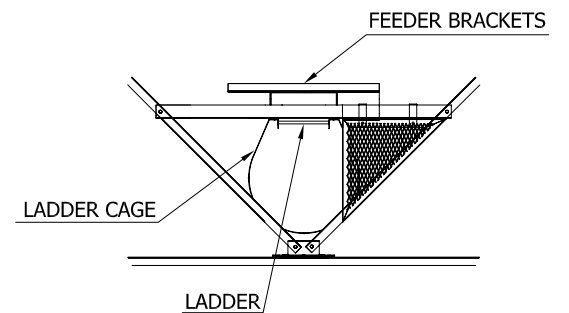

REST PLATFORM SHOWING
TYPICAL ARRANGEMENT OF LADDER & FEEDERS

Standard Codes of Practices	ANSI/TIA 222-G : 2005				
	Antenna loading, over top 10m	5.0sq.m	10.0sq.m	15.0sq.m	20.0sq.m
Basic wind speed, 3-s gust	46.0m/s	45.0m/s	44.0m/s	43.0m/s	41.0m/s
Operational wind speed, 3-s gust	46.0m/s	45.0m/s	44.0m/s	42.5m/s	39.5m/s
Maximum deflection	< 0.5 degree				

D		DRN	PK	PRODUCT:	WX-F200		
C		CHK	TRD	TITLE:	KEY DIAGRAM 40M		
B		APP	KSRF				
A	09/06/2009 (ORIGINAL)	ORIGINAL SCALE	NTS	@ A3 - DO NOT SCALE THIS PRINT	THIRD ANGLE PROJECTION U.N.O.	DRG.No	MKT_204
ISSUE							

NOTE FOR HDB :-
 BEFORE ERECTION, ALL BASE PLATES MUST BE SET TO THE SAME LEVEL ON THE HOLDING DOWN BOLTS (H.D.B.'s). THE LEVELLING NUT ON EACH H.D.B. MUST BE TIGHT TO THE UNDERSIDE OF EACH BASE PLATE DURING ERECTION. THE BASE PLATES SHOULD BE GROUTED AS SOON AS SUFFICIENT TOWER HAS BEEN ERECTED TO CONFIRM VERTICALITY; PREFERABLY BEFORE THE TOWER EXCEEDS 1/3 OF ITS HEIGHT.

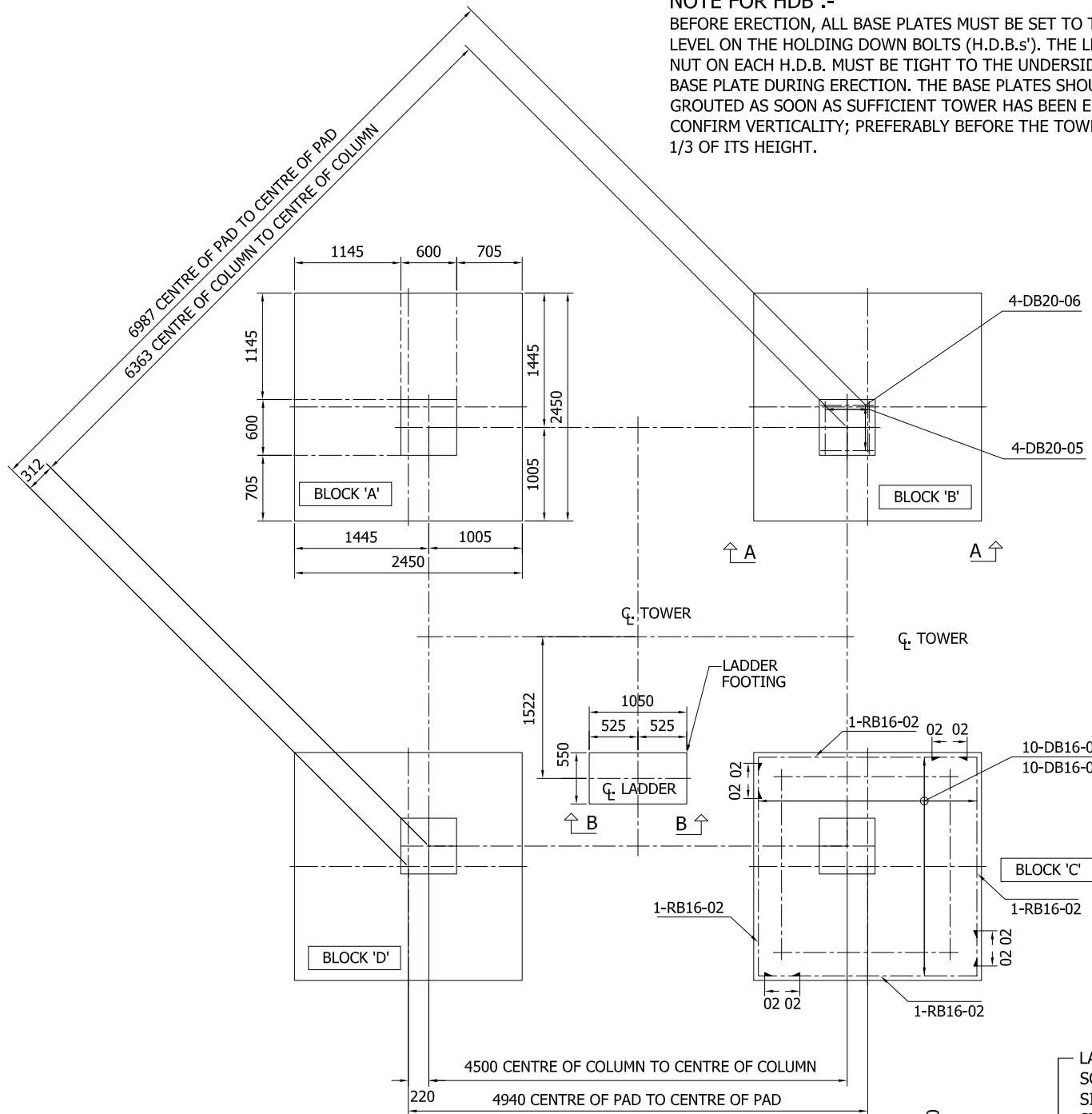

PLAN OF FOUNDATION
 SCALE 1 : 65

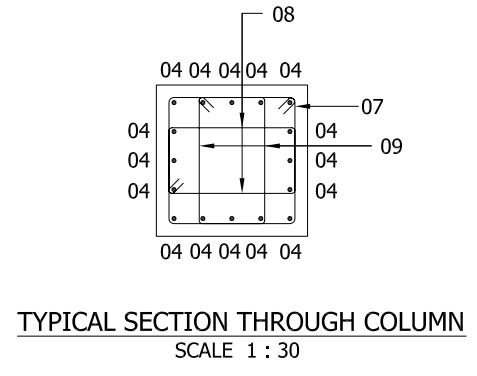

TYPICAL SECTION THROUGH COLUMN
 SCALE 1 : 30

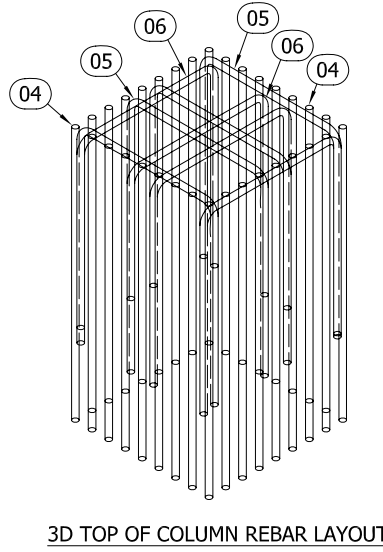

3D TOP OF COLUMN REBAR LAYOUT

NOTE:
 DRAWING SHOWS 600 X600 COLUMN WITH 32 T20 VERTICAL BARS FOR LESSER BARS OR BIGGER COLUMNS THEN POSITIONS OF REBAR CAN BE DIFFERENT

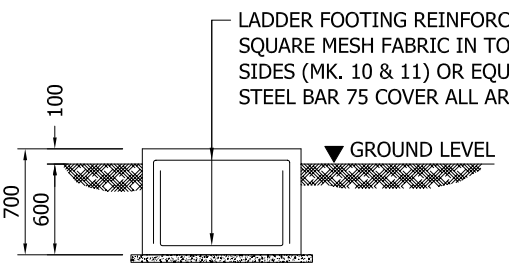

SECTION B - B
TYPICAL SECTION THROUGH LADDER FOOTING
 SCALE 1 : 50

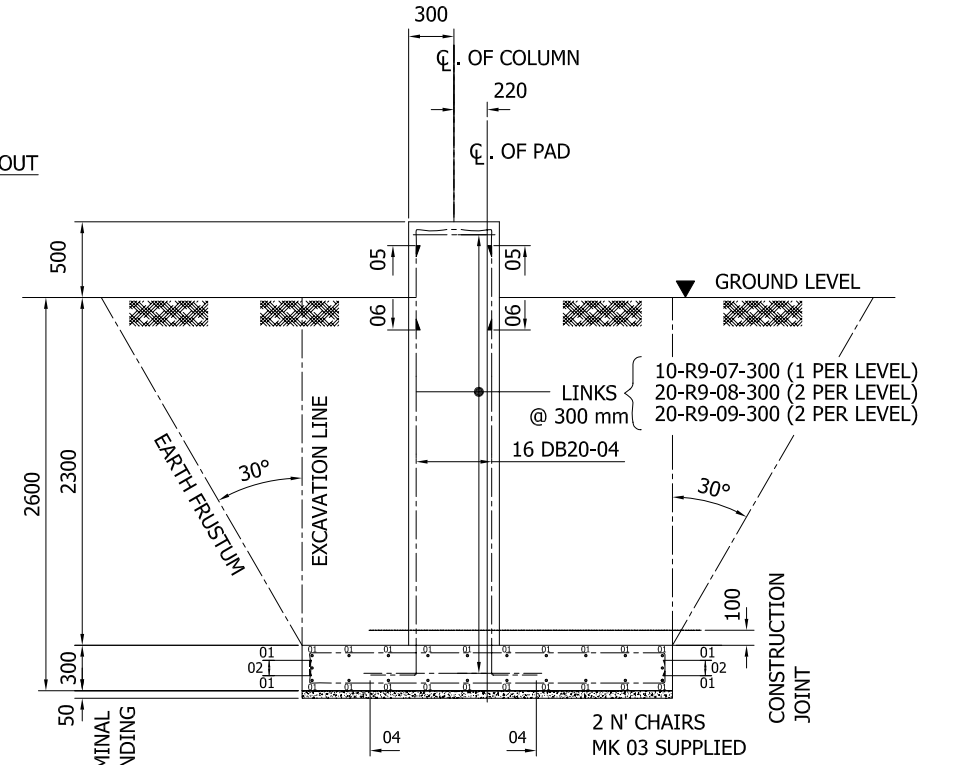

SECTION A - A
 SCALE 1 : 50

NOTE :-
 ALLOWABLE DESIGN BEARING PRESSURE $\geq 100.0 \text{ kN/m}^2$
 CONCRETE CONSTRUCTION SHALL BE IN ACCORDANCE WITH THE REQUIREMENTS OF BS.8110:1985
 CEMENT SHALL BE:- 'ORDINARY PORTLAND' OR 'SULPHATE RESISTING PORTLAND' (AS REQUIRED)
 MAXIMUM AGGREGATE SIZE SHALL BE 20mm.
 THE 28-DAY CRUSHING STRENGTH SHALL BE 30 N/mm² FOR STRUCTURAL CONCRETE, AND 15 N/mm² FOR CONCRETE FILL IN ACCORDANCE WITH BS.8110:1985.
 REINFORCEMENT STEEL SHALL HAVE $F_y = 400 \text{ MPa}$ MAIN BARS, AND $F_y = 240$ FOR CHAIRS AND LINKS.
 CONCRETE COVER SHALL BE 50mm TOP AND BOTTOM, 75mm TO SIDES, 75mm TO SIDES OF PAD, 50mm TO SIDES OF COLUMN.
 A 50mm 45° CHAMFER SHALL BE FORMED ON ALL EDGES AND RE-ENTRANT ANGLES.
 BEFORE PLACING CONCRETE, THE FOUNDATION SHALL BE FREE OF ANY LOOSE MATERIAL AND DELETERIOUS SUBSTANCES.
 WHILST PLACING, THE CONCRETE SHALL BE PROPERLY CONSOLIDATED USING MECHANICAL VIBRATORS.

D	DRN	PHS.	PRODUCT:	WX-F200		
C	CHK	TRD.	TITLE:	GA. PAD & COLUMN FOUNDATION HEIGHT 40.0 M.		
B	APP	PK.		100 kpa		
A	15/06/2009 (ORIGINAL)	NTS	@ A3 - DO NOT SCALE THIS PRINT	THIRD ANGLE PROJECTION U.N.O.	DRG.No	MKT_100
ISSUE						

REINFORCEMENT SCHEDULE

TITLE. PAD & COLUMN FOUNDATION FOR 40.0 M. 100 kPa (REF. MKT_100) **SHT.No.** 1 OF 1 **DRG.No.** MKT_100_RE

LOCATION	BAR MK	GRADE & DIA(mm)	TOTAL No.	LENGTH OF EACH	SHAPE CODE	SKETCH OR DIMENSIONS (mm)				
						A	B	C	D	E
PAD	01	T16	160	2550	21	150	2300			
PAD	02	T16	16	2775	11	400	2275			
PAD	03	R12	8	1800	99	500	150	500	500	
COLUMN	04	T20	64	3000	11	200	2850			
COLUMN	05	T20	16	1725	21	650	500	650		
COLUMN	06	T20	16	1725	21	650	500	650		
COLUMN	07	R9	40	2260	51	500	500	130		
COLUMN	08	R9	80	850	41	100	100	500	100	100
COLUMN	09	R9	80	850	41	100	100	500	100	100
LADDER BASE	10	R10 MESH	1	-	-	SKETCH				
LADDER BASE	11	R10 MESH	1	-	-	SKETCH				

SKETCHES FOR 10+11

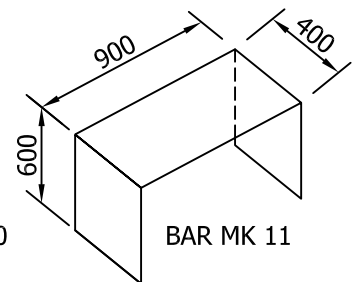
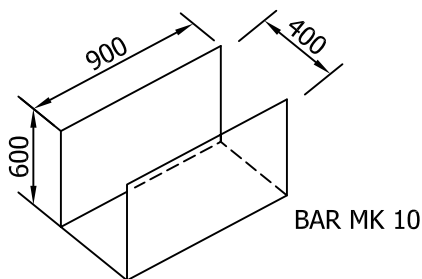
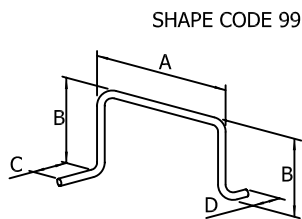

ISSUE	A						TOTAL WT. R9 = 112.97 Kg. TOTAL WT. R12 = 12.90 Kg. TOTAL WT. T16 = 714.79 Kg. TOTAL WT. T20 = 610.58 Kg. TOTAL WT. = 1451.25 Kg.
DATE	15/06/2009						
DRAWN	PHS.						
CHECKED	TRD.						
APPROVED	PK.						