

No.	Panel	Section			
		Leg	Diagonal	Horizontal	Arm
1	PANEL 1	CHS Ø114.3x3.2	CHS Ø27.2x2	CHS Ø27.2x2	-
2	PANEL 2 ANTITWIST	CHS Ø114.3x3.2	CHS Ø34x2.3	CHS Ø34x2.3	CHS Ø60.5x2.3
3	PANEL 3	CHS Ø114.3x3.2	CHS Ø27.2x2	CHS Ø34x2.3	-
4	PANEL 4	CHS Ø114.3x3.2	CHS Ø27.2x2	CHS Ø27.2x2	-
5	PANEL 5 ANTITWIST	CHS Ø114.3x3.2	CHS Ø34x2.3	CHS Ø34x2.3	CHS Ø60.5x2.3
6	PANEL 6	CHS Ø114.3x3.2	CHS Ø27.2x2	CHS Ø34x2.3	-
7	PANEL 7	CHS Ø114.3x3.2	CHS Ø27.2x2	CHS Ø27.2x2	-
8	PANEL 8	CHS Ø114.3x3.2	CHS Ø27.2x2	CHS Ø34x2.3	-
9	PANEL 9	CHS Ø114.3x3.2	CHS Ø27.2x2	CHS Ø27.2x2	-
10	PANEL 10	CHS Ø114.3x3.2	CHS Ø27.2x2	CHS Ø34x2.3	-
11	PANEL 11	CHS Ø114.3x3.2	CHS Ø27.2x2	CHS Ø27.2x2	-
12	PANEL 12	CHS Ø114.3x3.2	CHS Ø27.2x2	CHS Ø34x2.3	-
13	PANEL 13	CHS Ø114.3x3.2	CHS Ø27.2x2	CHS Ø27.2x2	-
14	PANEL 14	CHS Ø114.3x3.2	CHS Ø34x2.3	CHS Ø34x2.3	-

**NOTE**

FLANGE CONNECTION BETWEEN PANELS , 15MM PLATE, 210 OD , 6 x M16 GRADE 8.8 AT 165 PCD

REMARK CHS = CIRCULAR HOLLOW SECTION JIS G3444 (STK41)

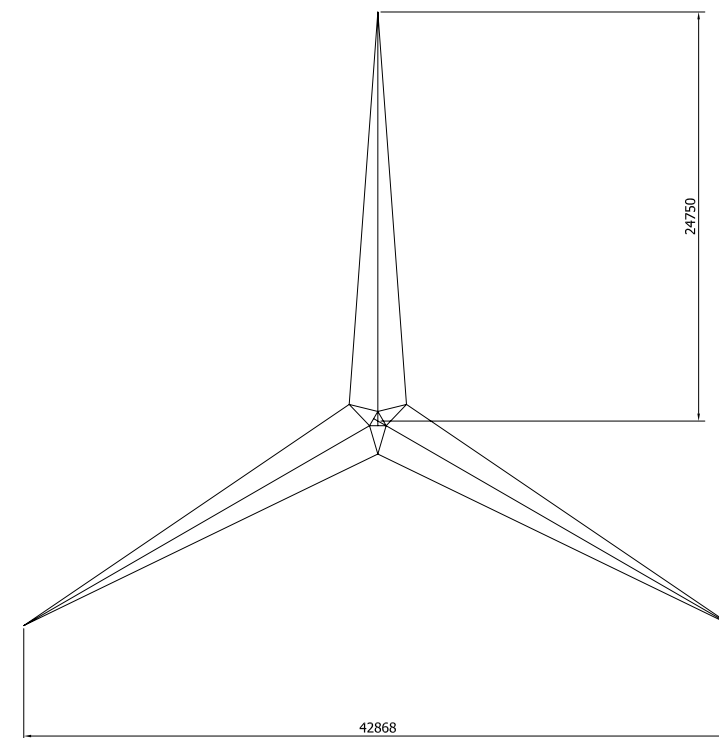

Standard Codes of Practices	ANSI/TIA 222-G:2005				
	5.0 sq.m	10.0 sq.m	15.0 sq.m	20.0 sq.m	25.0 sq.m
Antenna loading, over top 10m	5.0 sq.m	10.0 sq.m	15.0 sq.m	20.0 sq.m	25.0 sq.m
Basic wind speed, 3-s gust	54.0 m/s	45.0 m/s	38.0 m/s	33.5 m/s	30.5 m/s
Operational wind speed, 3 -s gust	51.5 m/s	43.0 m/s	37.0 m/s	33.5 m/s	30.5 m/s
Maximum deflection	<0.5 degree				

D		DRN	PHS.	PRODUCT: WX-GT100			
C		CHK	TRD.	TITLE: KEY DIAGRAM 55M GUYED MAST			
B		APP	PK				
A	05/08/2009 (ORIGINAL)	ORIGINAL SCALE	NTS	@ A3 - DO NOT SCALE THIS PRINT	THIRD ANGLE PROJECTION U.N.O.	DRG.No	MKT_GT_201
<b>ISSUE</b>							

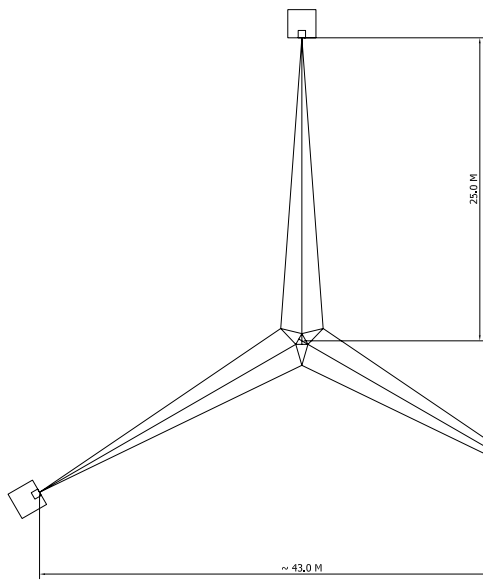

LAYOUT

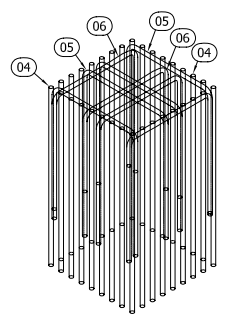

3D TOP OF COLUMN REBAR LAYOUT  
NOTE: DRAWING SHOWS 600 X 600 COLUMN WITH 32 T20 VERTICAL BARS FOR LESSER BARS OR BIGGER COLUMNS THEN POSITIONS OF REBAR CAN BE DIFFERENT

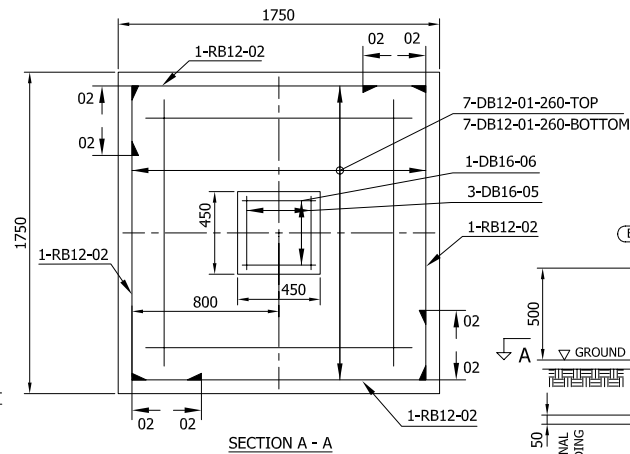

SECTION A - A

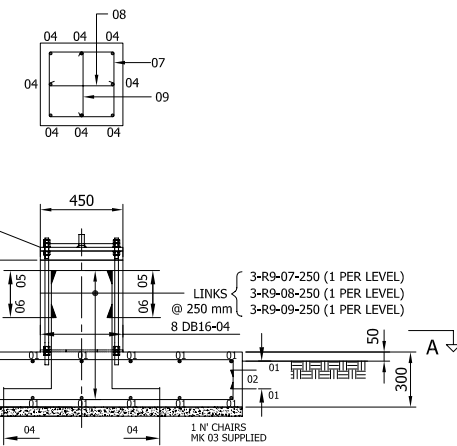

MAST BASE

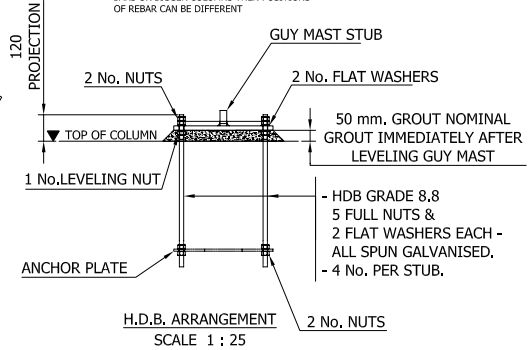

H.D.B. ARRANGEMENT  
SCALE 1 : 25

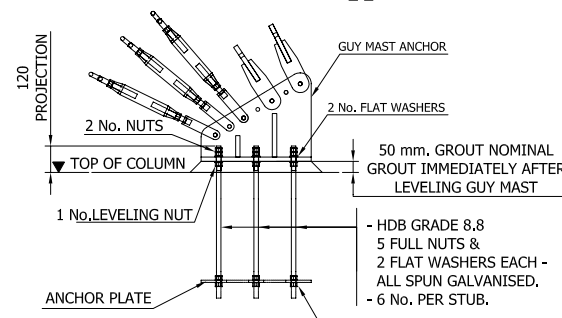

H.D.B. ARRANGEMENT  
SCALE 1 : 25

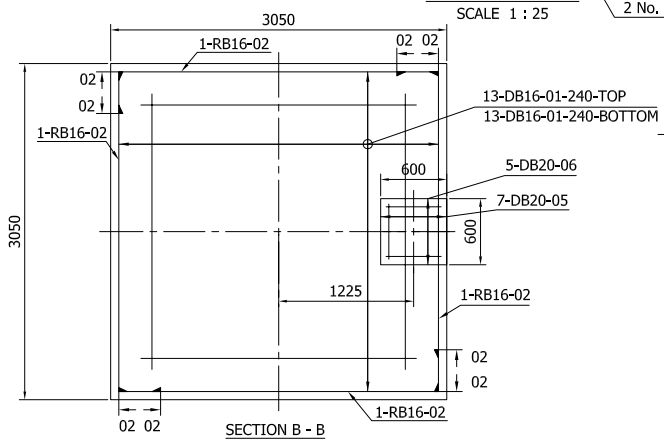

SECTION B - B

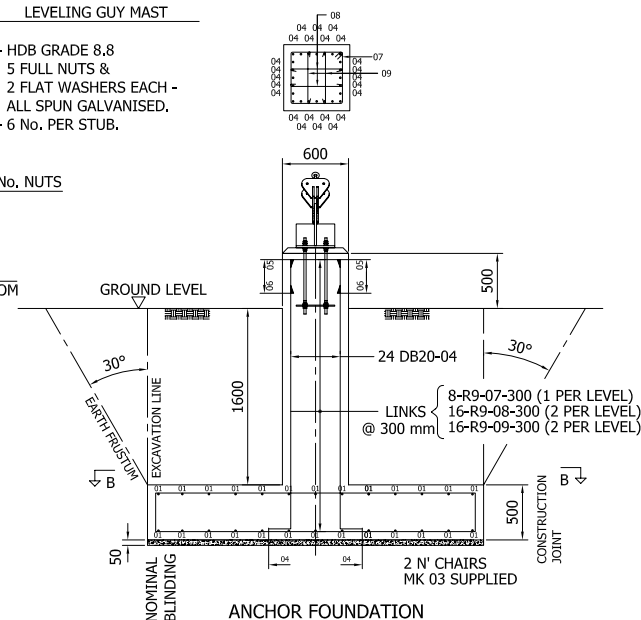

ANCHOR FOUNDATION

**NOTE FOR HDB :-**  
BEFORE ERECTION, ALL BASE PLATES MUST BE SET TO THE SAME LEVEL ON THE HOLDING DOWN BOLTS (H.D.B.s), THE LEVELLING NUT ON EACH H.D.B. MUST BE TIGHT TO THE UNDERSIDE OF EACH BASE PLATE DURING ERECTION. THE BASE PLATES SHOULD BE GROUTED AS SOON AS SUFFICIENT TOWER HAS BEEN ERECTED TO CONFIRM VERTICALITY; PREFERABLY BEFORE THE TOWER EXCEEDS 1/3 OF ITS HEIGHT.

**NOTE :-**  
ALLOWABLE DESIGN BEARING PRESSURE  $\geq 100 \text{ kN/m}^2$   
CONCRETE CONSTRUCTION SHALL BE IN ACCORDANCE WITH THE REQUIREMENTS OF BS.8110:1985  
CEMENT SHALL BE: 'ORDINARY PORTLAND' OR 'SULPHATE RESISTING PORTLAND' (AS REQUIRED)  
MAXIMUM AGGREGATE SIZE SHALL BE 20mm.  
THE 28-DAY CRUSHING STRENGTH SHALL BE 30 N/mm<sup>2</sup> FOR STRUCTURAL CONCRETE, AND 15 N/mm<sup>2</sup> FOR CONCRETE FILL IN ACCORDANCE WITH BS.8110:1985.  
REINFORCEMENT STEEL SHALL HAVE  $F_y = 400 \text{ MPa}$  MAIN BARS, AND  $F_y = 240$  FOR CHAIRS AND LINKS.  
CONCRETE COVER SHALL BE 50mm TOP AND BOTTOM, 75mm TO SIDES, 75mm TO SIDES OF PAD, 50mm TO SIDES OF COLUMN.  
A 50mm 45° CHAMFER SHALL BE FORMED ON ALL EDGES AND RE-ENTRANT ANGLES.  
BEFORE PLACING CONCRETE, THE FOUNDATION SHALL BE FREE OF ANY LOOSE MATERIAL AND DELETERIOUS SUBSTANCES.  
WHILST PLACING, THE CONCRETE SHALL BE PROPERLY CONSOLIDATED USING MECHANICAL VIBRATORS.

D	DRN	PHS.	PRODUCT:	MKT-GT100			
C	CHK	TRD.	TITLE:	GA. 55 m. GUYED MAST			
B	17/08/2009 2009/0025	APP	PK	PAD & COLUMN FOUNDATION 100 kPa			
A	11/08/2009 (ORIGINAL)	APP	PK				
<b>ISSUE</b>			ORIGINAL SCALE	NTS	@ A3 - DO NOT SCALE THIS PRINT	THIRD ANGLE PROJECTION U.N.O.	DRG.No MKT-GT_103



# REINFORCEMENT SCHEDULE

**TITLE.** PAD & COLUMN FOUNDATION FOR 55-60.0 M. SHT.No. 1 OF 1  
 GUY 100 kPa ANCHORS  
 (REF. MKT-GT\_103-104) DRG.No. MKT-GT\_103-104\_RE

LOCATION	BAR MK	GRADE & DIA(mm)	TOTAL No.	LENGTH OF EACH	SHAPE CODE	SKETCH OR DIMENSIONS (mm)				
						A	B	C	D	E
PAD	01	T16	156	3550	21	350	2900			
PAD	02	T16	12	3375	11	400	2875			
PAD	03	R12	6	2000	99	500	350	500	500	
COLUMN	04	T20	72	2000	11	200	1850			
COLUMN	05	T20	12	1725	21	650	500	650		
COLUMN	06	T20	12	1725	21	650	500	650		
COLUMN	07	R9	21	2260	51	500	500	130		
COLUMN	08	R9	42	850	41	100	100	500	100	100
COLUMN	09	R9	42	850	41	100	100	500	100	100

SKETCHES FOR 10+11

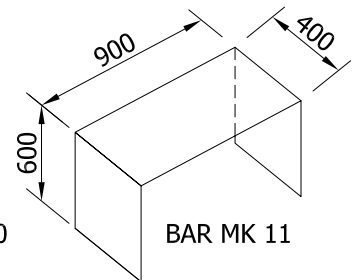
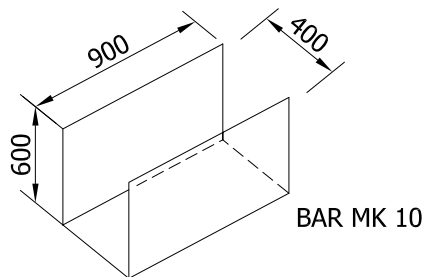
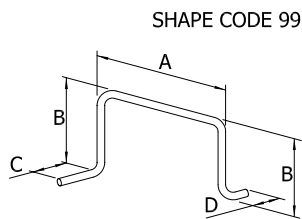

ISSUE	A										TOTAL WT. R9 = 59.31 Kg.
DATE	13/08/2009										TOTAL WT. R12 = 10.75 Kg.
DRAWN	PHS.										TOTAL WT. T16 = 938.99 Kg.
CHECKED	TRD.										TOTAL WT. T20 = 457.94 Kg.
APPROVED	PK.										TOTAL WT. = 1466.99 Kg.